

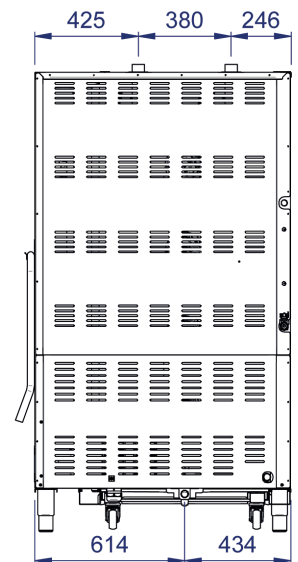

DT20TCH

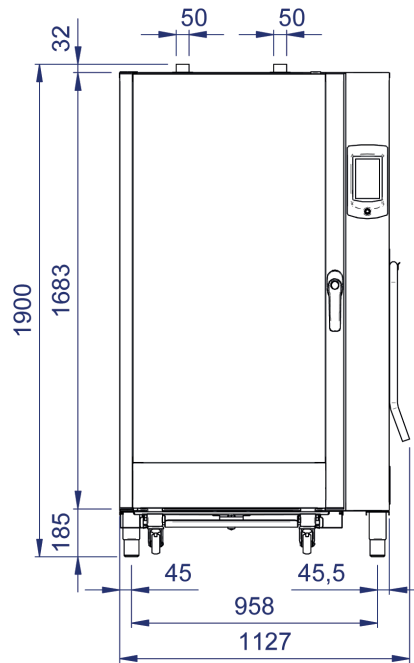
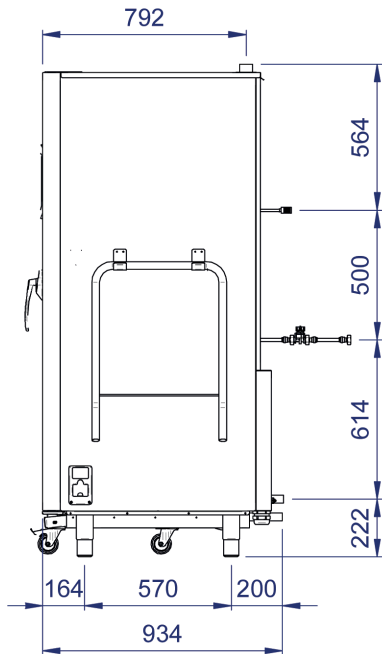

FUNCTIONAL CHARACTERISTICS

Display	7" CAPACITIVE TOUCH
Supply	ELECTRIC
Timer	-
Number of motors	4
Motor speeds	10
Max cooking temperature (°C)	260°C
Core probe	3 point PT1000
Cooking chamber material	AISI304
Opening door	Right handle

STANDARDS

Certification	CE
---------------	----

TRAYS

Trays rack	Trolley GA 20/66
Max tray load	4 kg

DIMENSIONS

Oven size with handle WxDxH (mm)	1091 x 1006 x 1900
Oven size without handle WxDxH (mm)	1091 x 938 x 1900
Chamber size WxDxH (mm)	700 x 491 x 1496
Unit weight (Kg)	250

PACKAGING

Packaging	PALLET + CARTON BOX
Packaging size WxDxH (mm)	1150 x 1100 x 2115
Unit weight with packaging (Kg)	279
Crate packaging size (optional)	1150 x 1100 x 2107

ELECTRICAL DATA

Heaters 6,75kW 50/60Hz 400V

Power	28,6kW
Frequency	50/60Hz
Power supply	380-415V 3N~
Amperage	46,1A
Power cord req.	5G10

Heaters 6,75kW 50/60Hz 400V/230V	
Power	28,6kW
Frequency	50/60Hz
Power supply	380-415V 3N~/220-240V 3~
Amperage	46,1A / 73,8A
Power cord req.	5G10 / 4G25
Heaters 6,5kW 50/60Hz 400V	
Power	25,5kW
Frequency	50/60Hz
Power supply	380-415V 3N~
Amperage	41,6A
Power cord req.	5G10
Heaters 6,5kW 50/60Hz 400V/230V	
Power	25,4kW
Frequency	50/60Hz
Power supply	380-415V 3N~/220-240V 3~
Amperage	41,6A / 65,97A
Power cord req.	5G10 / 4G25
Heaters 5kW 50/60Hz 440V	
Power	26,2 kW
Frequency	50/60Hz
Power supply	440V 3~
Amperage	38,9A
Power cord req.	4G10
WATER CONNECTION REQUIREMENTS	
Humidification/ Washing Water inlet	3/4" GAS
Water drain	2 x 50 mm
Max water hardness	5°f
Water pressure requirement min-max	150-200 kPa
CONSUMPTION	
Humidification Water	8,2l/h max consumption
Rinse Water @2barG	35,5l
Short Washing Water @2barG	66,6l

Long Washing Water @2barG	139l
Short Washing Detergent *	468,8g
Long Washing Detergent *	669,7g
CONNECTIVITY	
USB	2.0
Bluetooth	-
Wi-Fi	STANDARD
Cloud	Available as Optional
ACCESSORIES	
Self clean system kit	-
Oven stand	-
Hood (Air)	-
Hood (Water)	POSLMWF1 POSLMWF2
External Core probe	CP1
Proofer	C59
Stacking kit for 2 ovens	-
Smoker	SMK02
Blast chiller	-
Blast chiller stacking kit	-
Water softner cover	WS10
Water softner 6800L	WS11
Water softner 12000L	WS12
Water pressure adapter	WPA
Water shower kit	S1
Detergent 6KG (only with self clean system)	DT2
Detergent 10KG (only with self clean system)	DT4