

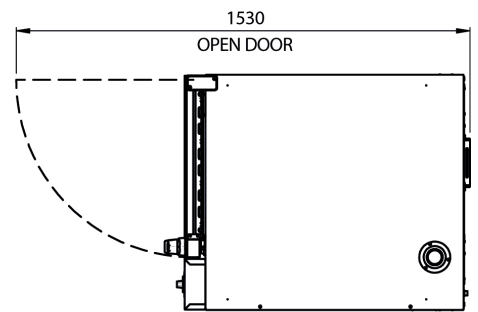

DT04TCH

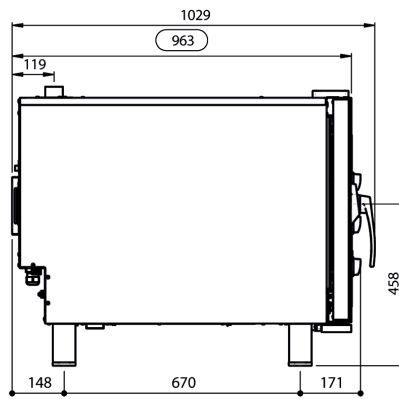
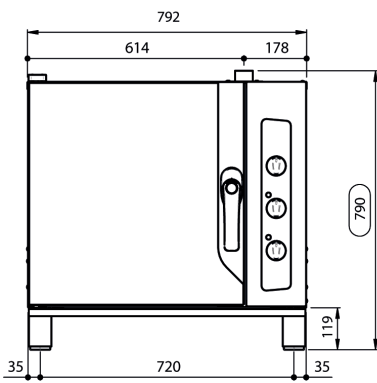

---

## FUNCTIONAL CHARACTERISTICS

---

Display	7" CAPACITIVE TOUCH
Supply	ELECTRIC
Timer	-
Number of motors	1
Motor speeds	10
Max cooking temperature (°C)	260°C
Core probe	3 point PT1000
Cooking chamber material	AISI304
Opening door	Right handle
Chimney	50 mm Motorized valve

---

## STANDARDS

---

Certification	CE
---------------	----

---

## TRAYS

---

Trays rack	Sheet PA-BIV 4/80 Sheet PA-BIV 5/75 Trolley rails
Max tray load	4 kg

---

## DIMENSIONS

---

Oven size with handle WxDxH (mm)	792 x 1029 x 781
Oven size without handle WxDxH (mm)	793 x 962 x 781
Chamber size WxDxH (mm)	460 x 630 x 452
Unit weight (Kg)	92

---

## PACKAGING

---

Packaging	PALLET + CARTON BOX
Packaging size WxDxH (mm)	880 x 1110 x 956
Unit weight with packaging (Kg)	112
Crate packaging size (optional)	880 X 1110 X 960

---

## ELECTRICAL DATA

---

### Heaters 9kW 50/60Hz

---

Power	9,4kW
Frequency	50/60Hz
Power supply	380-415V 3N~/220-240V 3~
Amperage	14,95A / 24,2A
Power cord req.	5G1,5/ 4G4

---

## WATER CONNECTION REQUIREMENTS

Humidification / Washing Water inlet	3/4" GAS
Water drain	50 mm
Max water hardness	5°f
Water pressure requirement min-max	150-200 kPa

## CONSUMPTION

Humidification Water	2l/h max consumption
Rinse Water @2barG	17,8l
Short Washing Water @2barG	33,6l
Long Washing Water @2barG	70l
Short Washing Detergent *	234,4g
Long Washing Detergent *	334,8g

## CONNECTIVITY

USB	2.0
Bluetooth	-
Wi-Fi	STANDARD
Cloud	Available as Optional

## ACCESSORIES

Self clean system kit	S1
Oven stand	TA7984H17X TA7984H30X TA7984H40S-TA7984H40X TA7984H49S-TA7984H49X TA7984H70S-TA7984H70X TA7984H80S-TA7984H80X
Hood (Air)	POSGMAF1 POSGMAF2
Hood (Water)	POSGMWF1 POSGMWF2
Core probe	CP1
Sous Vide core probe	CP4
Proofer	CA7912
Stacking kit for 2 ovens	SKSG15 SKSG85
Smoker	SMK02
Blast chiller	ASP05
Blast chiller stacking kit	SK16

Water softner cover	WS10
Water softner 6800L	WS11
Water softner 12000L	WS12
Water pressure adapter	WPA
Water shower kit	S1
Detergent 6KG (only with self clean system)	DT2
Detergent 10KG (only with self clean system)	DT4