

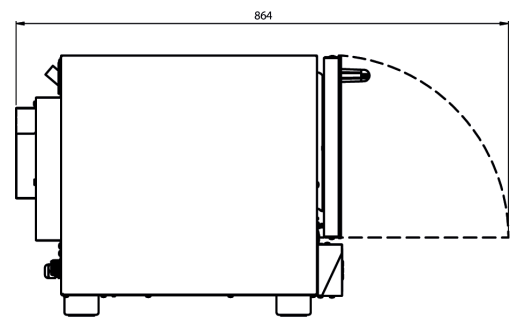

DT032DI.EVH

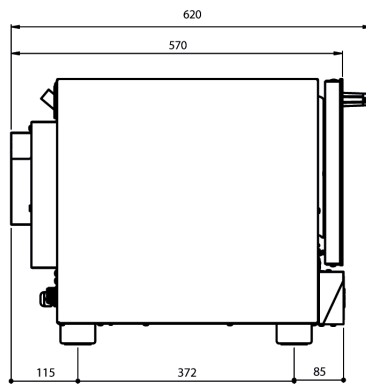
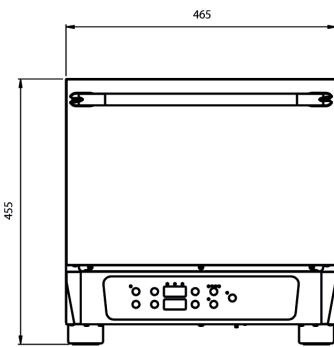

FUNCTIONAL CHARACTERISTICS

Display	DIGITAL
Supply	ELECTRIC
Timer	-
Number of motors	1
Motor speeds	1
Max cooking temperature (°C)	260°C
Core probe	-
Cooking chamber material	AISI 430
Opening door	From TOP to BOTTOM

TRAYS

Trays rack	WIRE PA 3/75
Max tray load	3 kg

DIMENSIONS

Oven size with handle WxDxH (mm)	465 x 620 x 454
Oven size without handle WxDxH (mm)	465 x 570 x 454
Chamber size WxDxH (mm)	379 x 312 x 245
Unit weight (Kg)	20

PACKAGING

Packaging	PALLET + CARTON BOX
Packaging size WxDxH (mm)	505 x 660 x 550
Unit weight with packaging (Kg)	22
Crate packaging size (optional)	-

ELECTRICAL DATA

Heaters 2,8kW (50/60Hz)	
Power	3kW
Frequency	50/60Hz
Power supply	220-240V ~
Amperage	13,3A
Power cord req.	3G1

WATER CONNECTION REQUIREMENTS

Humidification Water inlet	Yes
Washing Water inlet	-
Water drain	-
Max water hardness	5°f
Water pressure requirement min-max	150-200 kPa

CONSUMPTION

Humidification Water	-
Rinse Water @2barG	-
Short Washing Water @2barG	-
Long Washing Water @2barG	-
Short Washing Detergent *	-
Long Washing Detergent *	-

CONNECTIVITY

USB	-
Bluetooth	-
Wi-Fi	-
Cloud	-

ACCESSORIES

Self clean system kit	-
Oven stand	-
Wheels kit for stand	-
Hood (Air)	-
Hood (Water)	-
Core probe	-
Proofer	-
Stacking kit for 2 ovens	-
Smoker	-
Blast chiller	-
Blast chiller stacking kit	-

Water softner cover	WS10
Water softner 6800L	WS11
Water softner 12000L	WS12
Water pressure adapter	WPA
Water shower kit	-
Detergent 750ML (for Self clean system or Manual shower kit)	-
Detergent 6KG (only with self clean system)	-
Detergent 10KG (only with self clean system)	-